

Oak Lodge Water Services District
CAPITAL IMPROVEMENT PLAN
Fiscal Years 2023 - 2028



Table of Contents

<u>CIP Message</u>	<u>3</u>
<u>Document Guide</u>	<u>4</u>
<u>CIP Overview</u>	<u>5</u>
<u>Summary Information</u>	<u>6</u>
<u>Multi-Document Transparency</u>	<u>8</u>
<u>CIP Process</u>	<u>9</u>
<u>Vehicle Replacement Schedule</u>	<u>10</u>
<u>Watershed Protection Project Section</u>	<u>11</u>
<u>Wastewater Project Section</u>	<u>14</u>
<u>Water Project Section</u>	<u>34</u>
<u>Contact Information</u>	Back Cover

Message from the Interim District Engineer

Resource management is such an important function for any service provider and Oak Lodge Water Services District (District) is no different in this regard. Finding a balance between exemplary customer service and the cost to provide that service is key to the success of public organizations. In order to achieve this balance, one tool the District uses is a Capital Improvement Plan (CIP) because our service is heavily dependent upon physical infrastructure such as pipes. This document monetarily prepares for the expansion and maintenance of your Wastewater and Water systems as well as the provision of Watershed Protection services.

As this document is being produced, staff has the benefit of a newly adopted Water Master Plan to pull prioritized water projects from. And while staff is working to complete its Wastewater Master Plan by the end of the 2023, it should have the advantage of a prioritized project list to pull from for the FY24 budget cycle.

In parallel to the creation of the Wastewater Master Plan, staff is simultaneously negotiating an updated permit with DEQ for the operation of your Water Reclamation Facility. This new permit is likely to layer more stringent standards on the plant; standards in which it currently can not meet. To stay ahead of this, the District is looking to fund a Tertiary Filter Project (found on page 23). This is an example of how important it is for this document to look beyond the current fiscal year.

This proactive approach will not only save our rate payers money, but will enhance services due to time savings. Like a house waiting for a roof failure, that failure creates more damage to the house and costs more to repair than it would proactively; the same holds true for the District's investment in your infrastructure.

We at the District, hope that this document provides clear, concise and transparent information to you as our rate payer. As a result of reading this document, we hope you gain a better understanding of how the investment of revenue from your rates ensure your Water, Wastewater and surface water systems remain functioning well into the future. If you have any questions about this document, I encourage you to contact me at (503) 353-4202.

Sincerely,



Jason Rice, PE
Oak Lodge Water Services District
Interim District Engineer

How to Use This Document

This six-year Capital Improvement Plan document provides detailed descriptions about projects organized by fund. Each fund section begins with a summary overview of the function of the fund followed by funding and project information. Summary tables and graphs highlight the capital projects within each fund. Following the summary section are detailed breakdowns of each project, along with project schedules, cost estimates, and operating budget impacts.

Summary information of all capital projects sorted by fund, and funding source are included as appendices to this document.

Aldercrest Road								
								
Project Description								
Replacement of 3,025 feet of 6-inch and 8-inch ductile iron pipe with 8-inch ductile iron pipe.								
Project Justification								
During the creation Water System Master Plan, Operations Staff identified and prioritized six pipeline projects based on age and condition. This project was prioritized by staff to be the single most important project to the District when trying to avoid main breaks.								
Future Operating Cost Impact								
Completion of this project would lessen overall main breaks and thus lower operating costs.								
Budget Information and Projected Costs								
Pre-CIP (<FY22)	FY23	FY24	FY25	FY26	FY27	FY28	Total (in CIP)	Post-CIP (>FY28)
\$ 355,000	\$ 1,195,000	\$ -	\$ -	\$ -	\$ -	\$ -	\$ 1,195,000	\$ -
SDC Improvement Fee Eligibility: 9.7%								

Capital Improvement Plan Overview

The six-year Capital Improvement Plan (CIP) establishes guidance and planning for the District's investments in capital infrastructure. At the foundation of the CIP are the District's Surface Water, Wastewater and Water Master Plan documents. These master plans illustrate the long-term needs and goals of each department as defined by community input, advisory groups, expert consultants, and District Staff, and District Board goals, operational (i.e. service delivery) needs, and regulatory requirements further refine and shape the CIP.

Projects within the CIP are prioritized and matched with projections of future revenues. Inclusion of a project within this document does not necessarily reflect a budgeted spending commitment, but is the anticipated priority at this snapshot in time based on estimated future revenues. Current revenues are not enough to keep up with all the capital needs of the District. Additionally, there are restrictions on many revenue sources in relation to where the funds may be spent.

As compared to Capital Outlay line in the Budget, which may include purchases as low as \$5,000 and have a useful life of at least one year. A capital "project" contained within this document is defined by complexity of the work.

The CIP is intended as a method of communication with citizens, businesses, advisory groups, and the Board of Directors. It gives the public the opportunity to see the District's proposed plans for the future and provide feedback to the Board and Staff.

The goal of this Capital Improvement Plan is to provide the maximum sustainable level of priority capital investments to deliver outcomes that are of the highest importance to our citizens and provide for a healthy, safe, active, efficient, and optimized community with excellent livability and quality of life.

Factors in Evaluating CIP Projects

- | | |
|--|---|
| <ul style="list-style-type: none">• Master planning documents• Board goals• Operational needs• Regulatory requirements• Fiscal Impacts | <ul style="list-style-type: none">• Health, safety, and environmental effects• Community economic effects• Feasibility, including public support and disruption• Implications of deferring the project• Coordination and advantages of joint projects |
|--|---|

Summary Information

Funding Summary

	FY23	FY24	FY25	FY26	FY27	FY28	Total
Watershed Protection	\$300,000	\$300,000	\$300,000	\$300,000	\$300,000	\$300,000	\$1,800,000
Wastewater	\$3,614,000	\$5,300,000	\$5,025,000	\$1,605,000	\$2,700,000	\$1,450,000	\$19,694,000
Water	\$2,475,000	\$1,995,350	\$3,012,400	\$1,883,400	\$1,496,950	\$1,700,000	\$12,563,100
Vehicles	\$0	\$340,000	\$150,000	\$127,000	\$45,000	\$564,000	\$1,226,000
Total Capital Improvement Program	\$6,389,000	\$7,935,350	\$8,487,400	\$3,915,400	\$4,541,950	\$4,014,000	\$35,283,100

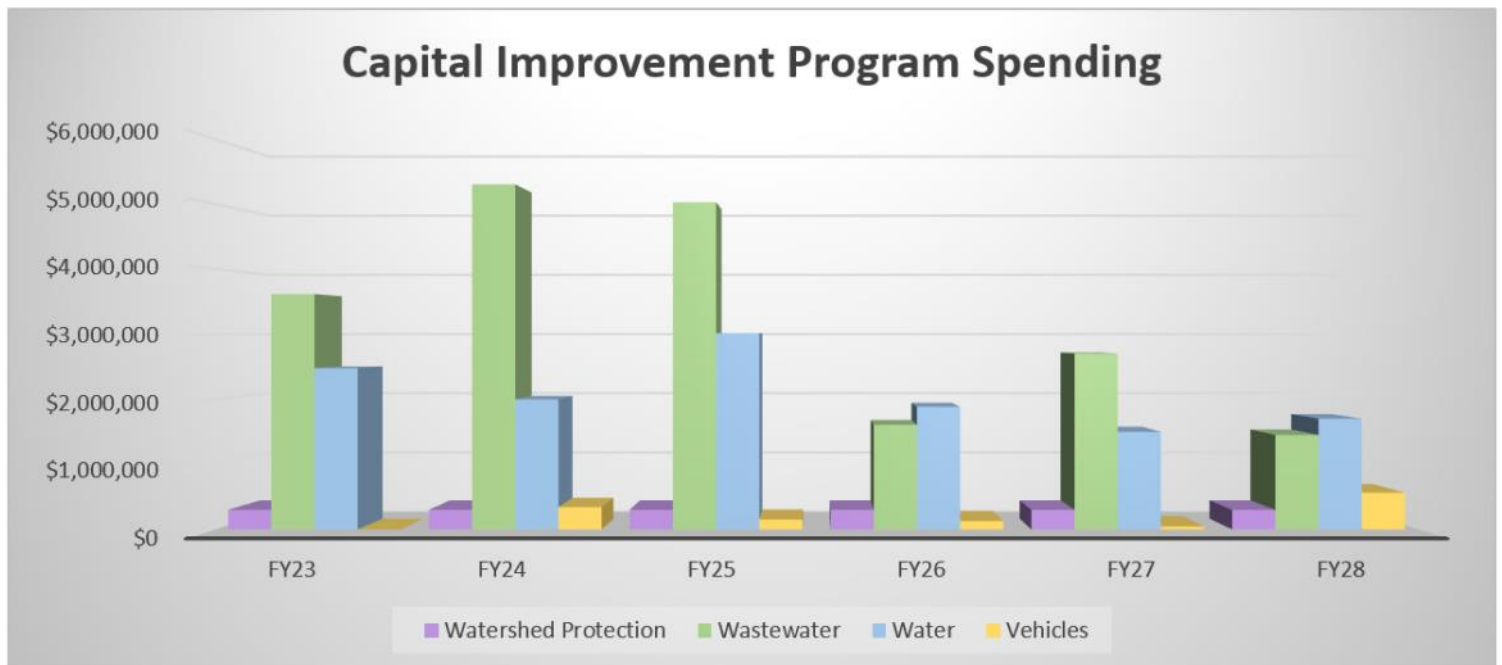

Funding for Capital Projects comes from four Distinct sources

- (1) Utility User Fees
- (2) Bonds
- (3) Grants come from outside agencies such as ODOT, Metro, DEQ, Oregon Parks, and the Oregon Marine Board
- (4) Systems Development Charges (SDCs): from new development



Multi-Document Transparency

The District recognizes that the projects included in the Six-Year Capital Improvement Plan represent a significant amount of public monies and it is the District's intention is to present this information across several documents to ensure that projects are clearly understood and accounted for in financial forecasts, budgets, capital improvement plans and master plans.

Multi-document transparency means that a capital project necessitated by a master plan will be included in the CIP document and then planned for in the forecast document. Funding for the project will then be included in the budget document and the expense will be recorded in quarterly and annual financial reports.

Master Plans
 - Surface Water
 - Wastewater
 - Water

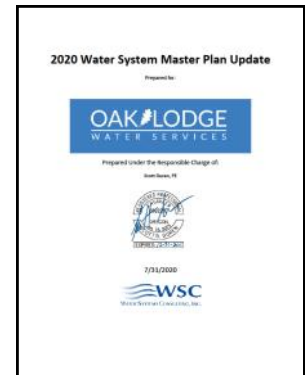
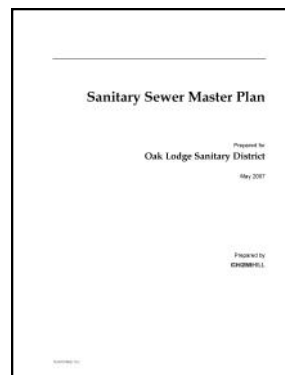
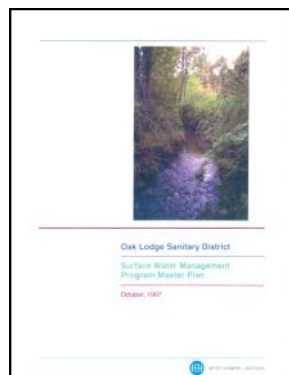

Fund 71 - Drinking Water Capital Fund

ACTUAL 17-18	ACTUAL 18-19	BUDGET 19-20	Object Code	Item	PROPOSED 20-21	APPROVED 20-21	ADOPTED 20-21
71-00- Resources							
\$ -	\$ -	\$ 2,703,013	3500	Beginning Fund Balance	\$ 3,942,000	\$ 3,942,000	\$ 3,942,000
-	74,267	50,000	4610	Investment revenue	50,000	50,000	50,000
-	1,320,000	-	4650	Proceeds from borrowing	-	-	-
71-29- Transfers In							
-	2,700,000	1,675,000	4910	Transfer In from Fund 10	500,000	500,000	500,000
\$ -	\$ 4,094,267	\$ 4,428,013	Total Resources		\$ 4,492,000	\$ 4,492,000	\$ 4,492,000.00
71-20- Capital Outlay							
\$ -	\$ 683,972	\$ -	7200	Infrastructure	\$ -	\$ -	\$ -
-	-	330,000	7300	Buildings and improvements	-	-	-
-	6,419	-	7530	Capital Software Purchase	-	-	-
-	34,113	-	7540	Vehicles	35,000	35,000	35,000
-	133,715	4,098,013	7600	Capital improvement projects	1,480,000	1,480,000	1,480,000
\$ -	\$ 858,220	\$ 4,428,013	Total Capital Outlay		\$ 1,515,000	\$ 1,515,000	\$ 1,515,000
71-29- Transfers and Contingency							
\$ -	\$ -	\$ -	9000	Contingency	\$ 2,977,000	\$ 2,977,000	\$ 2,977,000
\$ -	\$ -	\$ -	Total Transfers and Contingency		\$ 2,977,000	\$ 2,977,000	\$ 2,977,000
\$ -	\$ 858,220	\$ 4,428,013	Total Appropriations		\$ 4,492,000	\$ 4,492,000	\$ 4,492,000
\$ -	\$ 3,236,048	\$ -	Reserve for future expenditures		\$ -	\$ -	\$ -
\$ -	\$ 4,094,267	\$ 4,428,013	Total Requirements		\$ 4,492,000	\$ 4,492,000	\$ 4,492,000

Financial Reporting

"Capital Outlay" is reported in financial forecasts, budgets, quarterly reports, and annual reports. This line item corresponds with the annual funded totals shown in this Six-Year Capital Improvement Plan (CIP).

The adoption of this CIP document provides the baseline for the capital outlay that will be included in future budget documents for the Budget Committee to review, consider and approve, and for the Board to formally adopt.

The Process of a CIP Project

Question:

How does a project get placed on the Capital Improvement Plan?

Answer:

Rate Payer involvement is the cornerstone of the Six-Year Capital Improvement Plan. Projects are vetted through a multi-step process (see below) that includes public comment at several stages to ensure that projects meet the community's needs, in addition to expert analyses during plan development. Funding is not available for projects to begin until it is approved and adopted into the District's budget.

Project Start

A project is first considered as part of the Master Planning process. Staff, with the assistance of expert consultants and Citizen Advisory Group members, draft Master Plans for community consideration.

Master Plans are subject to community meetings at which citizens are invited to review the scope of the plan and the corresponding capital projects required to fulfill the plan.

The District Board then reviews the Master Plan and adopts it. Once adopted, the Master Plan becomes the guiding document for that utilities function and the associated project list is required to fulfill the Master Plan.

Citizens Budget Committee reviews and approves a budget which includes capital funding for projects identified within this document.

As projects are pursued, plan review and other land use steps may bring the project before the Board for their additional review and approval. Citizen comment is vital to this process.

Some projects, such as those funded with general obligation bonds, require a public vote. All projects will appear in the Board agenda for contract review and approval.

As projects commence, public outreach efforts will focus on impacted neighbors to ensure that project work has a minimal impact on services and the community. The District's website and Facebook is the primary communications vehicle.

Project Completion

Vehicles and Equipment

Overview

Oak Lodge Water Services District (District) has 36 pieces of rolling stock. 16 primarily used for the water, 18 for sewer and 1 for storm and 1 for Technical Services inspections. This program aims to systematically set aside funds at a predictable rate, that not only gives the Board a snapshot of the current fleet, but it also allows staff to show the Board in a single document the intended replacement schedule of each piece of equipment.

With regular and scheduled replacement of vehicles, the cost for major repairs should be kept to a minimum. In addition, the timing for replacements can occur in a planned, efficient and effective fashion thus evening out costs. For the first couple of years the District would need to catch up to meet the scheduled replacements because the newly created Capital Fund has no pre-existing reserves built up.

Vehicle Capital Purchases

ID#	Program	Vehicle Description	FY23	FY24	FY25	FY26	FY27	FY28	Totals
NEW	Wastewater	Biosolids Loader		150,000					\$ 150,000
12	Collections	Field Operations Vehicle		40,000					\$ 40,000
8	Technical Services	Inspection Truck		40,000					\$ 40,000
30	Water	Operations Dump Truck		110,000					\$ 110,000
55	Water	Field Operations Truck			40,000				\$ 40,000
42	Water	Backhoe			110,000				\$ 110,000
15	Wastewater	Plant Operations Truck				37,000			\$ 37,000
16	Wastewater	Plant Operations Truck				90,000			\$ 90,000
23	Wastewater	Portable Generator					10,000		\$ 10,000
68	Water	Field Operations Truck					35,000		\$ 35,000
69	Water	Field Operations Truck						74,000	\$ 74,000
17	Wastewater	Hydrocleaner						230,000	\$ 230,000
19	Wastewater	TV Van						260,000	\$ 260,000
Total Vehicle Capital Expenses			\$ -	\$ 340,000	\$ 150,000	\$ 127,000	\$ 45,000	\$ 564,000	\$ 1,226,000

Boardman and Arista Flooding



Project Description

Recognized as one of the District's worst flooding spots, this site repeatedly floods the Trolley Trail, Boardman Avenue, Arista Drive and private property. Currently, it is suspected that beaver dams and flat grades cause a majority of the flooding. This project seeks first to identify alternatives that could ease the flooding or completely eliminate it. Once these alternatives are identified, they will be presented to the stakeholders and a project will be decided upon based on funding contributions.

Project Justification

By fixing flooding issues within the District it improves environmental health, livability, and property values. These types of projects also help the District's MS4 Annual commitments to treating stormwater.

Future Operating Cost Impact

This project will both decrease Staff's time reporting to localized flooding; however, depending on the solution it may increase maintenance of District owned facilities.

Budget Information and Projected Costs

<i>Pre-CIP (<FY22)</i>	<i>FY23</i>	<i>FY24</i>	<i>FY25</i>	<i>FY26</i>	<i>FY27</i>	<i>FY28</i>	<i>Total (in CIP)</i>	<i>Post-CIP (>FY28)</i>
\$ 57,132	\$ 300,000	\$ -	\$ -	\$ -	\$ -	\$ -	\$ 300,000	

SDC Improvement Fee Eligibility: 0%

Localized Enhancement Program



Project Description

This program aims to fix small to medium scale localized issues throughout the District. Projects will include replacement of damaged stormwater pipes owned by the District, create new roadside surface water treatment and address issues brought forth by District customers.

Project Justification

The Board as well as staff often hear about issues throughout the District related to flooding. By programming money to either solve these issues or participate in multi-jurisdictional projects, the District can start to alleviate these issues for our rate-payers.

Future Operating Cost Impact

These projects will both decrease Staff's time reporting to localized flooding and increase maintenance of District owned facilities.

Budget Information and Projected Costs

Pre-CIP (<FY22)	FY23	FY24	FY25	FY26	FY27	FY28	Total (in CIP)	Post-CIP (>FY28)
		\$ 300,000	\$ 300,000	\$ 300,000	\$ 300,000	\$ 300,000	\$ 1,500,000	TBD

SDC Improvement Fee Eligibility: 0%

Overview

Oak Lodge Water Services District (District) charges customers a monthly fee for sanitary sewer service. Annual revenue changes slightly based on the number and types of customers, and comes in at approximately \$8.6M annually. Of this revenue, approximately 12% is budgeted to be used on capital improvements. The majority of sanitary sewer revenue is used for payment of the debt service to address the various loans associated with the Treatment Plant Expansion project.

Projects within the Sewer Capital Improvement list include finishing a conversion of the District's last anaerobic digester to meet permit requirements for land application of solids, projects to replace pipe deficiencies and trouble spots in the collection system and Water Reclamation Facility enhancements to the elements of the plant that were not reconstructed with the plant expansion project.

Wastewater Capital Improvement Projects

Page	Project Name	FY23	FY24	FY25	FY26	FY27	FY28	Totals
15	Sanitary Sewer Master Plan (Plant+Field)	310,000						\$ 310,000
16	Aeration Basin Baffle Wall	7,000						\$ 7,000
17	WTP Blower Rehab	7,000						\$ 7,000
18	PS5 Rebuild	160,000						\$ 160,000
19	Digester Blower Design and Replacement	80,000						\$ 80,000
20	Plant Lighting	75,000						\$ 75,000
21	Ultra-Violet Channel Refurbishment	25,000			55,000	250,000		\$ 330,000
22	PS2 Construction	800,000	650,000					\$ 1,450,000
23	Tertiary Filters at WRF	1,000,000	2,500,000	2,500,000				\$ 6,000,000
24	Trunk Main Capacity (River Forest SSO)	1,100,000	1,100,000					\$ 2,200,000
25	Lateral Repair Program	50,000	100,000	100,000	100,000	150,000	150,000	\$ 650,000
26	Hillside and Boardman Sewer Line Replacement		500,000					\$ 500,000
27	Influent Pump Station Reconstruction		100,000	450,000	450,000			\$ 1,000,000
28	Secondary Clarifier 1 and 2 and RAS Control Center Refurbishment				100,000	1,200,000	1,100,000	\$ 2,400,000
29	PS3 Rehabilitation		150,000	700,000	700,000			\$ 1,550,000
30	Manhole Repair Program		100,000	100,000	100,000	100,000	100,000	\$ 500,000
31	Mainline Repair Program		100,000	1,000,000	100,000	1,000,000	100,000	\$ 2,300,000
32	3rd Bar Screen in Headworks			100,000				\$ 100,000
33	Plant Air-line Inspection			75,000				\$ 75,000
Total Wastewater Capital Expenses		\$ 3,614,000	\$ 5,300,000	\$ 5,025,000	\$ 1,605,000	\$ 2,700,000	\$ 1,450,000	\$ 19,694,000

Sanitary Sewer Master Plan (Plant+Field)



Project Description

The District’s current Sanitary Master Plan was partially written upon historical knowledge of Staff. By the time this project is let, Staff will have collected and logged condition ratings via TV inspections that will inform an updated Master Plan which in turn will help staff prioritize the replacement of our aging infrastructure.

Project Justification

Master Plans are vital to managing utilities. By consolidating all available information into one document, a Master Plan provides a road map to shift away from reactive work towards proactive. This ultimately saves the District money by making informed decisions about what is the best use of each dollar spent.

Future Operating Cost Impact

This project has the potential to identify costs that may directly impact rates (with Board approval).

Budget Information and Projected Costs

Pre-CIP (<FY22)	FY23	FY24	FY25	FY26	FY27	FY28	Total (in CIP)	Post-CIP (>FY28)
\$ 310,000	\$ 310,000	\$ -	\$ -	\$ -	\$ -	\$ -	\$ 310,000	\$ -

SDC Improvement Fee Eligibility: 0%

Aeration Basin Baffle Wall



Project Description

Hydraulic modeling as part of an Aeration Study in FY19 shows that only two trains are needed for this task if the first train is divided into two by a baffle wall. This project would install that barrier.

Project Justification

The Aeration Basin Baffle Wall Project would conserve electricity and reduce greenhouse gas emissions by enabling plant operators to switch off parts of the aeration basin. The District has normally run all four of its Aeration Basin trains.

Future Operating Cost Impact

This project will reduce on-going maintenance and cause for better permit compliance.

Budget Information and Projected Costs

Pre-CIP (<FY22)	FY23	FY24	FY25	FY26	FY27	FY28	Total (in CIP)	Post-CIP (>FY28)
\$ 110,000	\$ 7,000	\$ -	\$ -	\$ -	\$ -	\$ -	\$ 7,000	\$ -

SDC Improvement Fee Eligibility: 0%

WTP Blower Rehab



Project Description

When the Water Reclamation Facility was built, the Interchange Bio-Reactors were designed with independent blowers. During a value engineering phase, one of the four Aeration Blowers was repurposed to supply air to the IBRs. Due to piping limitations, only that blower can be used for aerating the IBRs. Three years later, that blower catastrophically failed. Analysis of the failure indicated the potential for the blower not operating within its design parameters. One of the other Aeration Blowers was moved into that enclosure and the failed blower was replaced.

Project Justification

This project is a continuation of project that has already begun. By reconfiguring the blowers, the plant will run more efficiently and use less energy.

Future Operating Cost Impact

This is an optimization project focused on improving reliability improvements. Additional blowers will end up consuming more power

Budget Information and Projected Costs

<i>Pre-CIP (<FY22)</i>	<i>FY23</i>	<i>FY24</i>	<i>FY25</i>	<i>FY26</i>	<i>FY27</i>	<i>FY28</i>	<i>Total (in CIP)</i>	<i>Post-CIP (>FY28)</i>
\$ 110,000	\$ 7,000	\$ -	\$ -	\$ -	\$ -	\$ -	\$ 7,000	\$ -

SDC Improvement Fee Eligibility: 0%

PS5 Rebuild



Project Description

Oak Lodge Water Services is rebuilding the most critical of its five sewer pumping stations with work ongoing from last fiscal year. The 60-year-old station is located at one of the lowest points in the District where Boardman Creek meets the Willamette River. Environmental impact to this sensitive area, as well as costs, are being minimized by refurbishing the existing concrete structure with an anti-corrosive epoxy lining rather than rebuild it. The pumps are being replaced with submersible non-clog designs to meet modern health and safety rules.

Project Justification

Raw sewage produces gases in the pump station wet well that are corroding its concrete walls. If corrosion is allowed to continue, the structure will eventually deteriorate and need to be rebuilt with potential impact to Boardman Creek. Restoring the concrete interior walls and coating them with a lining of epoxy will allow the District to reuse the old structure. The current antiquated form of maintenance access to the existing pumps no longer complies with current health and safety requirements.

Future Operating Cost Impact

This existing pump station will continue to need power, telemetry, SCADA services and routine inspection and maintenance. This pump station has to exist in its location and is vital to the conveyance of sewage in our District.

Budget Information and Projected Costs

<i>Pre-CIP (<FY22)</i>	<i>FY23</i>	<i>FY24</i>	<i>FY25</i>	<i>FY26</i>	<i>FY27</i>	<i>FY28</i>	<i>Total (in CIP)</i>	<i>Post-CIP (>FY28)</i>
\$ 600,000	\$ 160,000	\$ -	\$ -	\$ -	\$ -	\$ -	\$ 160,000	\$ -

SDC Improvement Fee Eligibility: 0%

Digester Blower Design and Replacement



Project Description

Replaces one of the two Neuros turbo blowers currently used in conjunction with the aerobic digester system. This project would replace one of the aging blowers that was originally built in 2012.

Project Justification

The turbo blower technology the District had installed in the major plant upgrade in 2012 has turned out to be somewhat problematic. The cost of repairs on these blowers is high, averaging in the range of \$20,000 every time we have a turbo core failure, which has happened at least twice since installation. Coupled with the fact that they will be due for approximately another \$30,000 in PLC upgrades in the next three years, the District is looking to go with a newer technology rather than continuing upkeep on the current turbo blower technology.

Future Operating Cost Impact

Reduces risk of critical down time by replacing one of the turbo blowers with a more robust technology. Operating costs in the form of electricity may go up slightly, but the reduced downtime and need for mechanical repairs will provide the district with savings overall.

Budget Information and Projected Costs

<i>Pre-CIP (<FY22)</i>	<i>FY23</i>	<i>FY24</i>	<i>FY25</i>	<i>FY26</i>	<i>FY27</i>	<i>FY28</i>	<i>Total (in CIP)</i>	<i>Post-CIP (>FY28)</i>
\$ 30,000	\$ 80,000	\$ -	\$ -	\$ -	\$ -	\$ -	\$ 80,000	\$ -

SDC Improvement Fee Eligibility: 0%

Plant Lighting



Project Description

Starts replacing numerous outdoor safety lighting around the WRF, Changing out aging high pressure sodium lights with new energy-efficient LED lighting as well as adding photocell sensors so the lights will automatically turn on when it gets dark and turn off when the sun comes up.

Project Justification

The original WRF lighting that was installed during the major upgrade in 2012 used older technology high pressure sodium bulbs. These bulbs typically have a lifespan of 20,000 hours and use a tremendous amount of electricity. The new LED lighting will use a fraction of the energy and should have a longer lifespan, typically 50,000 hours.

Future Operating Cost Impact

With well over 50 high pressure sodium bulbs in operation at the WRF, a swap out to high efficiency LED lights will reduce the overall electricity bill and should see itself paid for within a decade. There may also be opportunities to partner with the Oregon Energy Trust to receive rebates associated with the changeover.

Budget Information and Projected Costs

Pre-CIP (<FY22)	FY23	FY24	FY25	FY26	FY27	FY28	Total (in CIP)	Post-CIP (>FY28)
\$ -	\$ 75,000	\$ -	\$ -	\$ -	\$ -	\$ -	\$ 75,000	\$ -

SDC Improvement Fee Eligibility: 0%

Ultra-Violet Channel Refurbishment



Project Description

This project is intended to replace complex gate maneuvering and level control with a passive level control system, replace the effluent flow meters, replace the influent gates with simple actuated slide gates, and inspect and modernize the UV bulb control system itself.

The intent of the rebuild is to have a more reliable, redundant UV disinfection system which is vital to permit compliance.

Project Justification

The current control system involves a series of interacting gates to open and close each channel and gates to control level to control dosage. There are many moving and wearing parts and this project would put in a passive level control and flow control system and replace the flow meter. This will reduce maintenance and simplify the system needed to meet permit limits for disinfection.

Future Operating Cost Impact

This project will reduce on-going maintenance and cause for better permit compliance.

Budget Information and Projected Costs

<i>Pre-CIP (<FY22)</i>	<i>FY23</i>	<i>FY24</i>	<i>FY25</i>	<i>FY26</i>	<i>FY27</i>	<i>FY28</i>	<i>Total (in CIP)</i>	<i>Post-CIP (>FY28)</i>
\$ 50,000	\$ 25,000	\$ -	\$ -	\$ 55,000	\$ 250,000	\$ -	\$ 330,000	\$ -

SDC Improvement Fee Eligibility: 0%

PS2 Construction



Project Description

This project will reconstruct the pump dry well area to a larger wet well with submersible non-clog pumps and increase the wet well size. It may replace the back up generator but it will definitely include higher sound walls and sound insulation.

Project Justification

Modernizing this pump station will replace old pumps and controls to non-clog submersible pumps. Doing so will enlarge the wet well which allows more time prior to bypass and a smoother pump flow to the collections system. This also eliminates all confined space entry to do pump maintenance. Currently confined space entry permit rules have to be followed just to clean a clogged pump. This is a very important pump station carrying the second most flow in the collection system.

Future Operating Cost Impact

This existing pump station will continue to need power, telemetry, SCADA services and routine inspection and maintenance. This pump station has to exist in its location and is vital to the conveyance of sewage in our District.

Budget Information and Projected Costs

<i>Pre-CIP (<FY22)</i>	<i>FY23</i>	<i>FY24</i>	<i>FY25</i>	<i>FY26</i>	<i>FY27</i>	<i>FY28</i>	<i>Total (in CIP)</i>	<i>Post-CIP (>FY28)</i>
\$ 60,000	\$ 800,000	\$ 650,000	\$ -	\$ -	\$ -	\$ -	\$ 1,450,000	\$ -

SDC Improvement Fee Eligibility: Likely >0% (Post Master Plan Approval)

Tertiary Filters at WRF



Project Description

This project would add some sort of filtration or tertiary treatment to the end of the process train. The District's site plan for the treatment plan identifies the space next to the UV channels to house these filters (once needed). The District will be receiving a new permit eventually and the limits will be tighter. The District can presently meet the proposed new permit levels most of the time but staff will not know the full extent of the limits until this renewal.

Project Justification

The current Draft NPDES Permit for the Water Reclamation Facility requires a level of treatment to that is not always possible with the current configuration.

Future Operating Cost Impact

This facility would be an addition to the treatment process. Whichever filtration is selected, it would carry with it additional

Budget Information and Projected Costs

Pre-CIP (<FY22)	FY23	FY24	FY25	FY26	FY27	FY28	Total (in CIP)	Post-CIP (>FY28)
\$ -	\$ 1,000,000	\$ 2,500,000	\$ 2,500,000	\$ -	\$ -	\$ -	\$ 6,000,000	\$ -

SDC Improvement Fee Eligibility: 0%

Trunk Main Capacity (River Forest SSO)



Project Description

DEQ intends to order the District to halt Sanitary Sewer Overflow events near Lift Station 2. The trunk main carrying wastewater from Lift Station 2 to the WRF has insufficient capacity, causing a mixture of raw wastewater and stormwater to spill to the river following storms. This project will first evaluate several potential solutions, and then look to design and construct the most beneficial one.

Project Justification

A primary purpose of Sanitary Collections is to get all wastewater from District customers to the WRF for treatment. The trunk of the sanitary collection system needs and increase in capacity to fulfill this elemental role.

Future Operating Cost Impact

Avoids fines and penalties from DEQ resulting from non-compliance with permit.

Budget Information and Projected Costs

Pre-CIP (<FY22)	FY23	FY24	FY25	FY26	FY27	FY28	Total (in CIP)	Post-CIP (>FY28)
\$ 40,000	\$ 1,100,000	\$ 1,100,000	\$ -	\$ -	\$ -	\$ -	\$ 2,200,000	\$ -

SDC Improvement Fee Eligibility: 0%

Lateral Repair Program

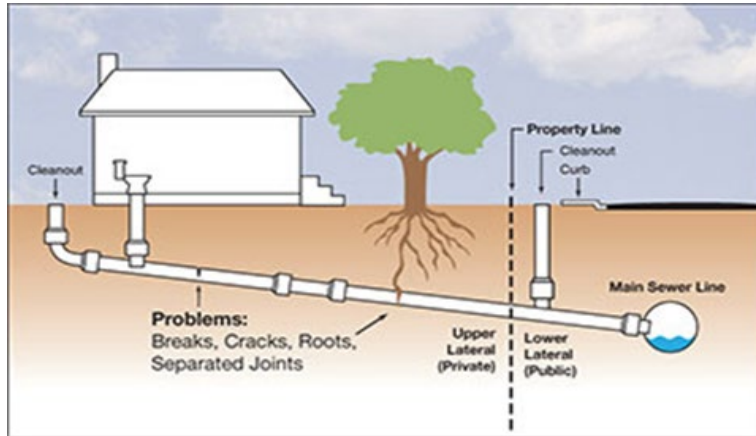

Project Description

The focus of this program is to repair and replace the public portion (the portion in the right-of-way) of wastewater laterals. Priority will be given to laterals allowing stormwater inflow and infiltration through breaks and which cause the greatest impacts to the operating budget.

Project Justification

The District is responsible for sanitary sewer laterals from the mainline to the property line or easement boundary. Currently there are 7550 laterals in the District and the replacement of each is averaging around \$10,000 per lateral. If each lateral were to be replaced once every 100 years, the District should be ramping up to spending \$755,000 per year on this program.

Future Operating Cost Impact

This project will decrease operating expenditures by reducing the total amount of inflow and infiltration into the wastewater system. Replacement of these laterals also help minimize risk to the District before failures cause damage to private property.

Budget Information and Projected Costs

Pre-CIP (<FY22)	FY23	FY24	FY25	FY26	FY27	FY28	Total (in CIP)	Post-CIP (>FY28)
\$ 120,000	\$ 50,000	\$ 100,000	\$ 100,000	\$ 100,000	\$ 150,000	\$ 150,000	\$ 650,000	>150k/year

SDC Improvement Fee Eligibility: 0%

Hillside and Boardman Sewer Line Replacement

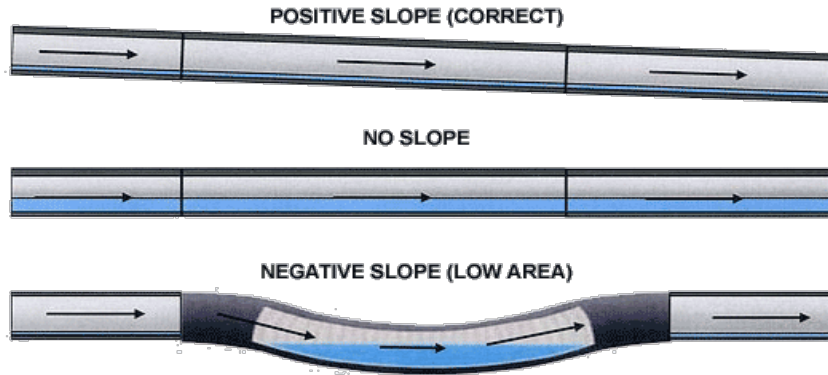

Project Description

This project includes replacing 638 feet of 12-inch diameter pipe that has settled. This settlement causes sediment, grease and fats to accumulate in the line which causes field staff to maintain this line more often than it should be.

Project Justification

The District does not currently have a Sanitary Sewer Master Plan that ranks capital projects. However, this project was identified by field staff to be one of the most problematic pipe sections for routine maintenance. By fixing it now, the District will not only be more confident in the pipe performing, but it will reduce the need for routine cleaning.

Future Operating Cost Impact

Replacement of this section will reduce the operating budget due to less frequent maintenance on this section.

Budget Information and Projected Costs

Pre-CIP (<FY22)	FY23	FY24	FY25	FY26	FY27	FY28	Total (in CIP)	Post-CIP (>FY28)
\$ 175,000	\$ -	\$ 500,000	\$ -	\$ -	\$ -	\$ -	\$ 500,000	\$ -

SDC Improvement Fee Eligibility: 0%

Influent Pump Station Reconstruction



Project Description

This project will reconfigure the main influent pump station wet well from a big square box which collects grit and debris. The already new non clog pumps will pump this material a bit at a time if the walls and enclosures were configured for self-cleaning. This project would also include surface control improvement and security enhancements.

Project Justification

During the construction of the Water Reclamation Facility, certain items at the Influent Pump Station were value engineered out. These items have caused for more maintenance on behalf of the treatment plant staff. Fixing these items will allow for staff to focus on other operational tasks.

Future Operating Cost Impact

This project will reduce maintenance for the plant staff.

Budget Information and Projected Costs

<i>Pre-CIP (<FY22)</i>	<i>FY23</i>	<i>FY24</i>	<i>FY25</i>	<i>FY26</i>	<i>FY27</i>	<i>FY28</i>	<i>Total (in CIP)</i>	<i>Post-CIP (>FY28)</i>
\$ -	\$ -	\$ 100,000	\$ 450,000	\$ 450,000	\$ -	\$ -	\$ 1,000,000	\$ -

SDC Improvement Fee Eligibility: 0%

Secondary Clarifier 1 and 2 and RAS Control Center Refurbishment



Project Description

Replaces the internal mechanisms of secondary clarifiers 1 and 2, which are reaching the end of their lifespan. Completely demolishes ageing steel and fiberglass components, and the drive mechanism. Replaces these with new stainless steel and aluminum components to protect against corrosion.

Project Justification

These clarifiers are from the original plant and are in need of replacement of the internal mechanisms due to age and corrosion. This project would also relocate the weirs to the wall to improve clarification and settling.

Future Operating Cost Impact

Reduces the risk of critical down time by replacing steel components deteriorating from rust. Provides long-term value by reinstalling mechanisms with corrosion-resistant materials. Enhances clarifier performance. Reduces need for mechanical repairs.

Budget Information and Projected Costs

Pre-CIP (<FY22)	FY23	FY24	FY25	FY26	FY27	FY28	Total (in CIP)	Post-CIP (>FY28)
\$ -	\$ -	\$ -	\$ -	\$ 100,000	\$ 1,200,000	\$ 1,100,000	\$ 2,400,000	\$ -

SDC Improvement Fee Eligibility: 0%

PS3 Rehabilitation



Project Description

Pump Station #4: This project will replace the electric and control system panels, build permanent enclosure, and create a useable access path to the actual pump station which is already submersible. The current set up has terrible access to power, controls, and pumps.

Pump Station #6: This project will reconstruct the pump dry well area to a larger wet well with submersible non-clog pumps and increase the wet well size. This station sits in a flood plain and

Project Justification

Modernizing the pump station by replacing old pumps and controls to non-clog submersible pumps. Doing so will enlarge the wet well which allows more time prior to bypass and a smoother pump flow to the collections system. This also eliminates all confined space entry to do pump maintenance. Currently confined space entry permit rules have to be followed just to clean a clogged pump.

Future Operating Cost Impact

This existing pump station will continue to need power, telemetry, SCADA services and routine inspection and maintenance. This pump station has to exist in its location and is vital to the conveyance of sewage in our District.

Budget Information and Projected Costs

Pre-CIP (<FY22)	FY23	FY24	FY25	FY26	FY27	FY28	Total (in CIP)	Post-CIP (>FY28)
\$ -	\$ -	\$ -	\$ 150,000	\$ 700,000	\$ 700,000	\$ -	\$ 1,550,000	\$ -

SDC Improvement Fee Eligibility: Likely >0% (Post Master Plan Approval)

Manhole Repair Program



Project Description

This program was created to ensure the replacement of all manholes within the Wastewater network over a 150-year period. In the case of a manhole having satisfactory structural integrity, manhole rehabilitation (i.e., manhole lining or grouting) will be done in lieu of full manhole replacement. Manholes to be replaced or rehabilitated will be identified by staff on an annual basis.

Project Justification

While manholes are relatively low-maintenance and last quite some time, they are vital to conveying sewage and providing access for inspections of mainlines. Keeping good records in the District's asset management database, staff will stay ahead of failures by rehabilitating when needed rather than complete replacement.

Future Operating Cost Impact

This project will not increase operating expenditures. These projects will replace or repair manholes one-for-one and will not increase the number of wastewater assets system-wide.

Budget Information and Projected Costs

<i>Pre-CIP (<FY22)</i>	<i>FY23</i>	<i>FY24</i>	<i>FY25</i>	<i>FY26</i>	<i>FY27</i>	<i>FY28</i>	<i>Total (in CIP)</i>	<i>Post-CIP (>FY28)</i>
\$ -	\$ -	\$ 100,000	\$ 100,000	\$ 100,000	\$ 100,000	\$ 100,000	\$ 500,000	>100K/year

SDC Improvement Fee Eligibility: 0%

Mainline Repair Program



Project Description

Projects under this program generally consist of spot repairs where structural or inadequate flow conditions exist. Projects are identified based on routine system monitoring and/or maintenance done by the Field Crews and projects identified in a Sanitary Sewer Master Plan.

Project Justification

Currently, this "project" is more of a place holder for forecasting longer term needs of the District. It is assumed that with the completion of the District's first Sanitary Sewer Master Plan, projects will be identified, ranked and prioritized into the CIP.

Future Operating Cost Impact

This project will decrease operating expenditures by reducing the total amount of inflow and infiltration into the wastewater system.

Budget Information and Projected Costs

<i>Pre-CIP (<FY22)</i>	<i>FY23</i>	<i>FY24</i>	<i>FY25</i>	<i>FY26</i>	<i>FY27</i>	<i>FY28</i>	<i>Total (in CIP)</i>	<i>Post-CIP (>FY28)</i>
\$ -	\$ -	\$ 100,000	\$ 1,000,000	\$ 100,000	\$ 1,000,000	\$ 100,000	\$ 2,300,000	TBD

SDC Improvement Fee Eligibility: Likely >0% (Post Master Plan Approval)

3rd Bar Screen in Headworks



Project Description

Adds a third bar screen in the headworks. In the 2012 upgrade, engineers added a slot for a third bar screen for future expansion.

Project Justification

When originally designed, the operating plan for most equipment at the WRF was sized to have a lead piece of equipment, which could operate under normal conditions, with a spare or redundant piece of equipment as backup in case of failure or maintenance. As the flows have increased at the WRF, operations has seen more and more use of both of the bar screens, leaving no redundancy in the case of failure or maintenance. During these times if one of the two automated bar screens were to fail, one bar screen would not be able to handle the flows and catastrophic flooding may

Future Operating Cost Impact

Routine maintenance costs and electricity will go up slightly.

Budget Information and Projected Costs

Pre-CIP (<FY22)	FY23	FY24	FY25	FY26	FY27	FY28	Total (in CIP)	Post-CIP (>FY28)
\$ -	\$ -	\$ -	\$ 100,000	\$ -	\$ -	\$ -	\$ 100,000	

SDC Improvement Fee Eligibility: 0%

Plant Air-line Inspection



Project Description

Project is to have all buried underground airlines inspected and checked for corrosion and loose fittings. This is to include the Air Lines going from the larger blowers to the Aeration basin as well as the Interchange Bioreactors. It will also include the air lines going from the smaller Neuros blowers to digesters #1 and #2.

Project Justification

The air lines inside the plant pose a unique problem: the blowers that supply air to the tanks pump out warm air, close to 90 degrees and hotter, depending on ambient temperatures. When the air turns off, the lines cool. This hot cold cycle happens daily on most of the lines, and since most of the lines are buried in the ground, this will cause condensation to build on the lines which leads to corrosion, as well as expansion and contraction of the bolts and fittings. After being in the ground for nearly a decade, it would be prudent to inspect these lines to ensure there's no excess corrosion that would lead to a collapse of piping and to check for flanges that may have worked themselves loose.

The air lines in the WRF are considered an extremely critical piece of infrastructure. Any failure of these lines that led to no air being delivered to tanks would likely have catastrophic results.

Future Operating Cost Impact

Depending on how the inspection goes, there may be sections of the piping that need to be repaired and/or replaced.

Budget Information and Projected Costs

Pre-CIP (<FY22)	FY23	FY24	FY25	FY26	FY27	FY28	Total (in CIP)	Post-CIP (>FY28)
\$ -	\$ -	\$ -	\$ 75,000	\$ -	\$ -	\$ -	\$ 75,000	

SDC Improvement Fee Eligibility: 0%

Overview

The Oak Lodge Water Services District's (District) water distribution system is primarily comprised of 6-inch and 8-inch cast and ductile iron pipe. Prior to the Master Plan Adoption, the District has concentrated on eliminating many sections of 2-inch pipe and looping dead-ends and spent on average \$500,000 annually on water capital, however beginning last year this number has been increased to around \$1,500,000 to keep up with other water capital needs such as inter-ties and resiliency against natural disasters.

The District has more than sufficient storage with two 5 million gallon reservoirs at the Valley View site and two 2.8 million gallon reservoirs at the View Acres site to supply the system. However, the Valley View Reservoirs are also used as a storage source to serve the Sunrise Water Authority, Clackamas River Water and the City of Gladstone.

Water Capital Improvement Projects

Page	Project Name	FY23	FY24	FY25	FY26	FY27	FY28	Totals
35	Aldercrest Road	1,195,000						\$ 1,195,000
36	OLWSD Water Pump Station Generator	100,000						\$ 100,000
37	Seismic Study of 24-inch Supply Line	200,000						\$ 200,000
38	Valley View Tank Upgrades (Fall Protection)	100,000						\$ 100,000
39	28th Avenue, Lakewood Drive, Kellogg Lake Apartments	600,000	600,000					\$ 1,200,000
40	Milwaukie-OLWSD Intertie Pump Station	180,000	810,000	810,000				\$ 1,800,000
41	Large Meter Testing and Replacement	100,000	50,550		50,000	50,550		\$ 251,100
42	Ranstad and Cinderella Courts		79,000					\$ 79,000
43	Marcia Court		128,000					\$ 128,000
44	Oatfield Road		327,800	983,400	983,400	983,400		\$ 3,278,000
45	Lisa Lane			225,000				\$ 225,000
46	Pressure Reducing Valve Rebuild (Every 5 years)			25,000				\$ 25,000
47	Replace all 4.25-inch Fire Hydrants			319,000				\$ 319,000
48	CRW-OLWSD Intertie Pump Station			650,000	650,000			\$ 1,300,000
49	AWIA Risk and Resilience Assessment - Update				50,000			\$ 50,000
50	Water System Master Plan - Update				150,000			\$ 150,000
51	Radio Telemetry Activation Study					24,000		\$ 24,000
52	Vault Meter Bypass Installations					110,000		\$ 110,000
53	River Road					329,000	1,500,000	\$ 1,829,000
54	Seal Coat on Valley View Reservoir Domes						200,000	\$ 200,000
Total Water Capital Expenses		\$ 2,475,000	\$ 1,995,350	\$ 3,012,400	\$ 1,883,400	\$ 1,496,950	\$ 1,700,000	\$ 10,534,100

Aldercrest Road

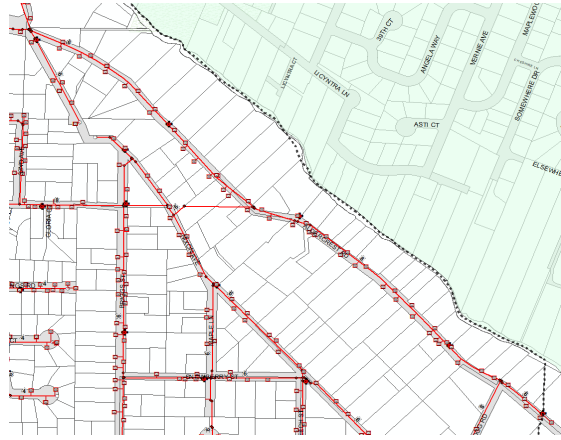

Project Description

Replacement of 3,025 feet of 6-inch and 8-inch ductile iron pipe with 8-inch ductile iron pipe.

Project Justification

During the creation of the Water System Master Plan, Operations Staff identified and prioritized six pipeline projects based on age and condition. This project was prioritized by staff to be the single most important project to the District when trying to avoid main breaks.

Future Operating Cost Impact

Completion of this project would lessen overall main breaks and thus lower operating costs.

Budget Information and Projected Costs

<i>Pre-CIP (<FY22)</i>	<i>FY23</i>	<i>FY24</i>	<i>FY25</i>	<i>FY26</i>	<i>FY27</i>	<i>FY28</i>	<i>Total (in CIP)</i>	<i>Post-CIP (>FY28)</i>
\$ 355,000	\$ 1,195,000	\$ -	\$ -	\$ -	\$ -	\$ -	\$ 1,195,000	\$ -

SDC Improvement Fee Eligibility: 9.7%

OLWSD Water Pump Station Generator



Project Description

This project is designing and creating an alternative power source at the water pump station near Clackamas River Water. This pump is vital to pushing water into the Valley View Reservoir in the even the North Clackamas Country Water Commission can not. This pump can also move water into Clackamas River Water and the Sunrise Water Authority systems if need be.

Project Justification

During this past winter's storm, keeping our generators running with diesel took an enormous amount of time and effort. This generator would run on a fixed connection to Natural Gas and would not need to be refilled in the event of a electric power failure.

Future Operating Cost Impact

This generator would need to be maintained on a yearly basis and would eventually require parts to be replaced.

Budget Information and Projected Costs

<i>Pre-CIP (<FY22)</i>	<i>FY23</i>	<i>FY24</i>	<i>FY25</i>	<i>FY26</i>	<i>FY27</i>	<i>FY28</i>	<i>Total (in CIP)</i>	<i>Post-CIP (>FY28)</i>
\$ 100,000	\$ 100,000	\$ -	\$ -	\$ -	\$ -	\$ -	\$ 100,000	\$ -

SDC Improvement Fee Eligibility: 0%

Seismic Study of 24-inch Supply Line

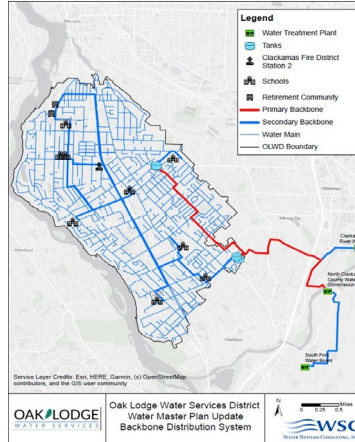

Project Description

To improve the reliability of the District's 24-inch water supply pipeline, a seismic study is recommended to assess the current condition and the potential site-specific ground deformations anticipated along the alignment based on geotechnical explorations. Identification of any excessive seismic risk and appropriate mitigation measures is a high priority for improving the overall system resilience.

Project Justification

Little is known about the District's 24" supply line from the Commission. This project would explore and identify any vulnerabilities the District should know about and plan for.

Future Operating Cost Impact

This study would not have a direct impact of future operating costs.

Budget Information and Projected Costs

Pre-CIP (<FY22)	FY23	FY24	FY25	FY26	FY27	FY28	Total (in CIP)	Post-CIP (>FY28)
\$ -	\$ 200,000	\$ -	\$ -	\$ -	\$ -	\$ -	\$ 200,000	\$ -

SDC Improvement Fee Eligibility: 0%

Valley View Tank Upgrades (Fall Protection)



Project Description

The fall protection that currently exists on site has met its useful life. To install a new system, the District has contracted with an Engineer to explore options.

Project Justification

The current fall protection is at its useful life and needs to be brought up to today's code to make it safe for staff to work on top of the reservoirs.

Future Operating Cost Impact

These systems have a useful life and need parts replaced at a minimum. Regular inspection of the equipment should be done with each use, but this new setup should last the District at least 20 years.

Budget Information and Projected Costs

Pre-CIP (<FY22)	FY23	FY24	FY25	FY26	FY27	FY28	Total (in CIP)	Post-CIP (>FY28)
\$ 50,000	\$ 100,000	\$ -	\$ -	\$ -	\$ -	\$ -	\$ 100,000	\$ -

SDC Improvement Fee Eligibility: 0%

28th Avenue, Lakewood Drive, Kellogg Lake Apartments



Project Description

This project replaces 4015 feet of 8-inch cast iron pipe with 8 and 12-inch ductile iron pipe. It will also create a loop in the system where the District has had to flush more often to keep the water fresh tasting.

Project Justification

This project was identified by the Water System Master Plan as one of the highest priority projects for water quality.

Future Operating Cost Impact

This project will lower operating costs due to reduced flushing this area less.

Budget Information and Projected Costs

Pre-CIP (<FY22)	FY23	FY24	FY25	FY26	FY27	FY28	Total (in CIP)	Post-CIP (>FY28)
\$ 100,000	\$ 600,000	\$ 600,000	\$ -	\$ -	\$ -	\$ -	\$ 1,200,000	\$ -

SDC Improvement Fee Eligibility: 18.3%

Milwaukie-OLWSD Intertie Pump Station



Project Description

An existing 10-inch diameter main in the Milwaukie system is located adjacent to existing 8-inch diameter District main along River Road. A booster pump station could be used to pump water from Milwaukie’s lower zone to the District’s lower zone to fill the Valley View tanks. Upsizing of 2,000 feet of pipe along River Road to 12-inch diameter would be required at an estimated cost of \$1,789,000.

Project Justification

With a single source of supply through the 24-inch pipeline from the NCCWC, the District is vulnerable to an outage caused by an unplanned pipe break. Portions of the pipeline closer to the Clackamas River are expected to have an increased risk of breakage due to lateral spreading and liquefaction induced settlement.

Future Operating Cost Impact

This emergency intertie would be an addition to the District's drinking water system. Pumps will need to be maintained, staff will need to be trained and power will be consumed when it is in use.

Budget Information and Projected Costs

Pre-CIP (<FY22)	FY23	FY24	FY25	FY26	FY27	FY28	Total (in CIP)	Post-CIP (>FY28)
\$ -	\$ 180,000	\$ 810,000	\$ 810,000	\$ -	\$ -	\$ -	\$ 1,800,000	\$ -

SDC Improvement Fee Eligibility: 0%

Large Meter Testing and Replacement



Project Description

This project aims to keep up with testing of large meters throughout the District. Testing will be conducted to make sure the meter is reading within an acceptable range. If it is not, it will be repaired to ensure proper readings.

Project Justification

By testing and repairing meters, the District can ensure that it is collecting correct revenues for usage.

Future Operating Cost Impact

This project is the operating cost for making sure correct revenues are collected.

Budget Information and Projected Costs

Pre-CIP (<FY22)	FY23	FY24	FY25	FY26	FY27	FY28	Total (in CIP)	Post-CIP (>FY28)
\$ -	\$ 100,000	\$ 50,550	\$ -	\$ 50,000	\$ 50,550	\$ -	\$ 251,100	\$50,550 in FY29&32

SDC Improvement Fee Eligibility: 0%

Ranstad and Cinderella Courts

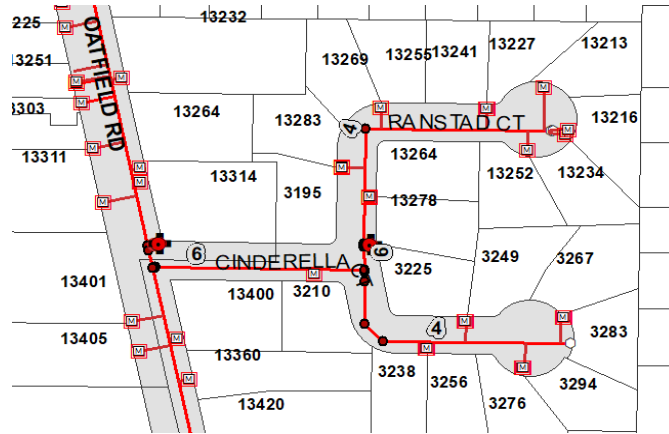

Project Description

This project replaces 760 feet of 4-inch cast iron pipe with 6-inch ductile iron pipe.

Project Justification

During the Water System Master Plan, Operations Staff identified and prioritized six pipeline projects based on age and condition. This project was prioritized by staff to be the single most important project to the District when trying to avoid main breaks.

Future Operating Cost Impact

Completion of this project would lessen overall main breaks and thus lower operating costs.

Budget Information and Projected Costs

Pre-CIP (<FY22)	FY23	FY24	FY25	FY26	FY27	FY28	Total (in CIP)	Post-CIP (>FY28)
\$ -	\$ -	\$ 79,000	\$ -	\$ -	\$ -	\$ -	\$ 79,000	\$ -

SDC Improvement Fee Eligibility: 28.9%

Marcia Court

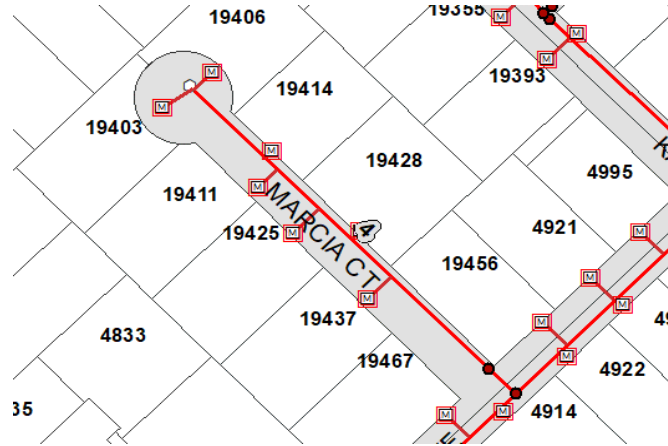

Project Description

This project replaces 475 feet of 4-inch cast iron pipe with 6-inch ductile iron pipe.

Project Justification

During the Water System Master Plan, Operations Staff identified and prioritized six pipeline projects based on age and condition. This project was prioritized by staff to be the third most important project to the District when trying to avoid main breaks.

Future Operating Cost Impact

Completion of this project would lessen overall main breaks and thus lower operating costs.

Budget Information and Projected Costs

Pre-CIP (<FY22)	FY23	FY24	FY25	FY26	FY27	FY28	Total (in CIP)	Post-CIP (>FY28)
\$ -	\$ -	\$ 128,000	\$ -	\$ -	\$ -	\$ -	\$ 128,000	\$ -

SDC Improvement Fee Eligibility: 32.2%

Oatfield Road



Project Description

This project replaces 15,995 feet of 6 and 8-inch cast iron pipe with 8-inch ductile iron pipe over three years.

Project Justification

During the Water System Master Plan, Operations Staff identified and prioritized six pipeline projects based on age and condition. This project was prioritized by staff to be the fifth most important project to the District when trying to avoid main breaks. Oatfield Road and its ADA ramps were also identified by Clackamas County to be replaced before 2030. This has since been delayed, but the project is still a high priority for replacement. Therefore, getting ahead of the paving will help the District avoid substantial paving requirements.

Future Operating Cost Impact

Completion of this project would lessen overall main breaks and thus lower operating costs.

Budget Information and Projected Costs

Pre-CIP (<FY22)	FY23	FY24	FY25	FY26	FY27	FY28	Total (in CIP)	Post-CIP (>FY28)
\$ -	\$ -	\$ 327,800	\$ 983,400	\$ 983,400	\$ 983,400	\$ -	\$ 3,278,000	\$ -

SDC Improvement Fee Eligibility: 7.9%

Lisa Lane

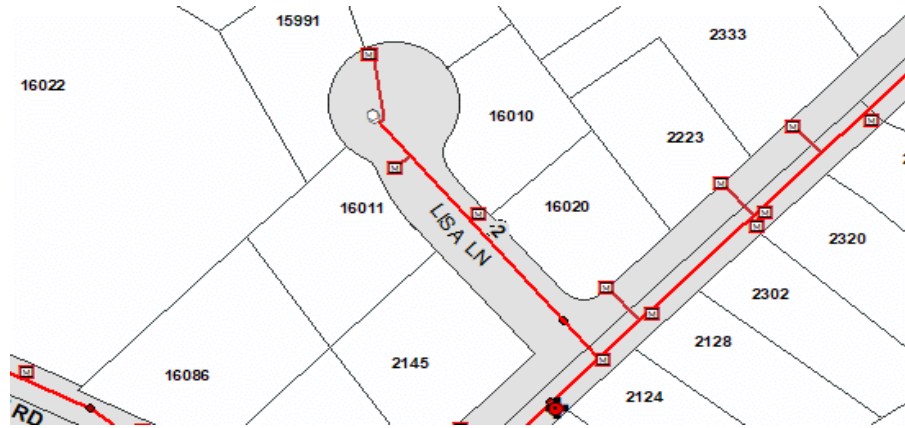

Project Description

This project replaces 300 feet of 2-inch pipe with 6-inch ductile iron pipe.

Project Justification

During the Water System Master Plan, Operations Staff identified and prioritized six pipeline projects based on age and condition. This project was prioritized by staff to be the single most important project to the District when trying to avoid main breaks.

Future Operating Cost Impact

Completion of this project would lessen overall main breaks and thus lower operating costs.

Budget Information and Projected Costs

<i>Pre-CIP (<FY22)</i>	<i>FY23</i>	<i>FY24</i>	<i>FY25</i>	<i>FY26</i>	<i>FY27</i>	<i>FY28</i>	<i>Total (in CIP)</i>	<i>Post-CIP (>FY28)</i>
\$ -	\$ -	\$ -	\$ 225,000	\$ -	\$ -	\$ -	\$ 225,000	\$ -

SDC Improvement Fee Eligibility: 33%

Pressure Reducing Valve Rebuild (Every 5 years)



Project Description

The District has three PRVs that regulate pressure throughout the system. The District has indicated that each of the PRVs should be rebuilt every five years. Typically this work is performed by an outside contractor and includes a tear-down of each valve to inspect the diaphragm, seats, and other parts subject to wear, and the replacement of any components that have outlived their useful service life. In addition to rebuilding the valve, the PRV vault should also be assessed to determine if additional improvements to address drainage, safe access and egress, or ventilation are needed.

Project Justification

Rebuilding these valves every 5 years ensures that the District can control operating pressures throughout the system. Failure of these valves could cause both private property damage as well as damage to the public infrastructure if pressures are allowed to be too high.

Future Operating Cost Impact

These valves should be inspected at least once per year and rebuilt every 5 years to prevent failures.

Budget Information and Projected Costs

<i>Pre-CIP (<FY22)</i>	<i>FY23</i>	<i>FY24</i>	<i>FY25</i>	<i>FY26</i>	<i>FY27</i>	<i>FY28</i>	<i>Total (in CIP)</i>	<i>Post-CIP (>FY28)</i>
\$ -	\$ -	\$ -	\$ 25,000	\$ -	\$ -	\$ -	\$ 25,000	25K in FY30

SDC Improvement Fee Eligibility: 0%

Replace all 4.25-inch Fire Hydrants



Project Description

Over the next 20- years the District plans to replace all 4 ½-inch hydrants to meet the current standard. Replacements are likely to occur in conjunction with condition based replacements as described in the previous section and with fire flow projects described in the previous chapter. There will still be a remaining number of hydrants outside of the scope of the condition and fire flow projects that will also need to be replaced within the next 20 years.

Project Justification

The District’s current potable water system standards require each fire hydrant to use a 5 ¼-inch valve. Older hydrants exist throughout the distribution system that have a 4 ½-inch valve.

Future Operating Cost Impact

This project will not increase operating costs for the District.

Budget Information and Projected Costs

Pre-CIP (<FY22)	FY23	FY24	FY25	FY26	FY27	FY28	Total (in CIP)	Post-CIP (>FY28)
\$ -	\$ -	\$ -	\$ 319,000	\$ -	\$ -	\$ -	\$ 319,000	\$ -

SDC Improvement Fee Eligibility: 0%

CRW-OLWSD Intertie Pump Station

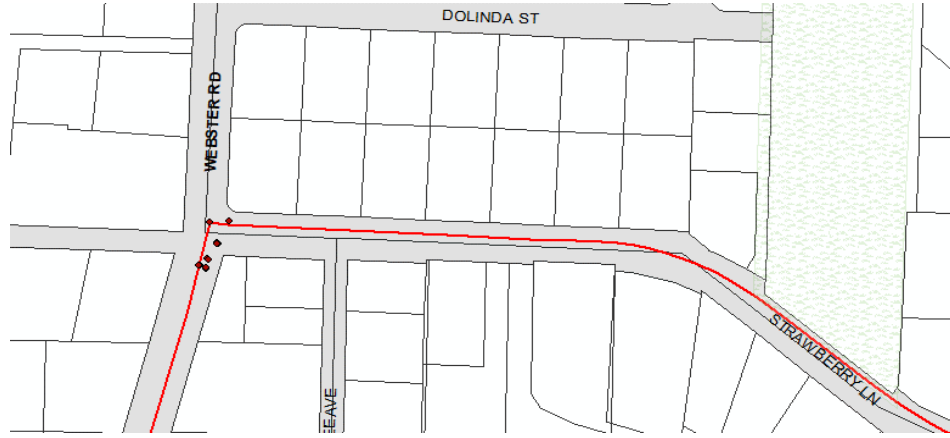

Project Description

To construct a redundant supply that could be used during an outage of the 24-inch water supply pipeline to the District or in the event of the Clackamas River not being available to the Commission, an intertie with Clackamas River Water is recommended. A pumping station will be necessary to overcome the difference in pressure between the two systems.

Project Justification

Currently, the District has no alternative water supply if the Clackamas River was either contaminated or not available due to low flows. This project would connect the District in a new way to Clackamas River Water (CRW) so that CRW could supply the District water from the City of Portland; water that does not come from the Clackamas River.

Future Operating Cost Impact

This project would build a new pump station that will carry with it maintenance and replacement costs.

Budget Information and Projected Costs

Pre-CIP (<FY22)	FY23	FY24	FY25	FY26	FY27	FY28	Total (in CIP)	Post-CIP (>FY28)
\$ -	\$ -	\$ -	\$ 650,000	\$ 650,000	\$ -	\$ -	\$ 1,300,000	\$ -

SDC Improvement Fee Eligibility: 0%

AWIA Risk and Resilience Assessment - Update



Project Description

In 2018 the AWIA was signed into law and requires the District to conduct a risk and resilience assessment (RRA) and a subsequent development of an emergency response plan (ERP) prior to June 30, 2021. The law also mandates that the that the RRA and ERP are updated every 5 years.

Project Justification

This project is required by Federal Law.

Future Operating Cost Impact

This update may identify risks for the District which would then be contrasted with other water projects during a scheduled Water Master Plan Update.

Budget Information and Projected Costs

Pre-CIP (<FY22)	FY23	FY24	FY25	FY26	FY27	FY28	Total (in CIP)	Post-CIP (>FY28)
\$ -	\$ -	\$ -	\$ -	\$ 50,000	\$ -	\$ -	\$ 50,000	\$ -

SDC Improvement Fee Eligibility: 0%

Water System Master Plan - Update



Project Description

This project would update the District's Water System Master Plan. Specific updates would be removing completed CIP's from the list, updating population demand forecasts and re-running the water model to make sure the District is staying ahead of growth and failures within the system.

Project Justification

Planning capital improvements beyond 5 years can be a challenge for water utilities; however, a targeted update to the master plan on a 5-year cycle can dramatically improve the utility of the WSMP.

Future Operating Cost Impact

This project would identify projects to be completed, but has not direct impact on future operating costs.

Budget Information and Projected Costs

Pre-CIP (<FY22)	FY23	FY24	FY25	FY26	FY27	FY28	Total (in CIP)	Post-CIP (>FY28)
\$ -	\$ -	\$ -	\$ -	\$ 150,000	\$ -	\$ -	\$ 150,000	\$ -

SDC Improvement Fee Eligibility: 0%

Radio Telemetry Activation Study



Project Description

The District's Water System Master Plan identified a benefit to reactivating radio telemetry communications to serve as a backup communications system to the cellular modems. Radio telemetry units would be necessary at four District facilities including Valley View, View Acres, the central operations shop, and the North Clackamas County Water Commission Water Treatment Plant.

Project Justification

Staff are constantly monitoring a number of variables that relate to serving safe drinking water. One example of this would be the level in a water reservoir. Radio telemetry allows staff to monitor this data remotely. During emergencies radio telemetry helps staff stay focused on fixing main breaks and fueling generators rather than making sure the tanks are at an appropriate level.

Future Operating Cost Impact

Annual User License Fees would apply to the telemetry system.

Budget Information and Projected Costs

<i>Pre-CIP (<FY22)</i>	<i>FY23</i>	<i>FY24</i>	<i>FY25</i>	<i>FY26</i>	<i>FY27</i>	<i>FY28</i>	<i>Total (in CIP)</i>	<i>Post-CIP (>FY28)</i>
\$ -	\$ -	\$ -	\$ -	\$ -	\$ 24,000	\$ -	\$ 24,000	TBD

SDC Improvement Fee Eligibility: 0%

Vault Meter Bypass Installations

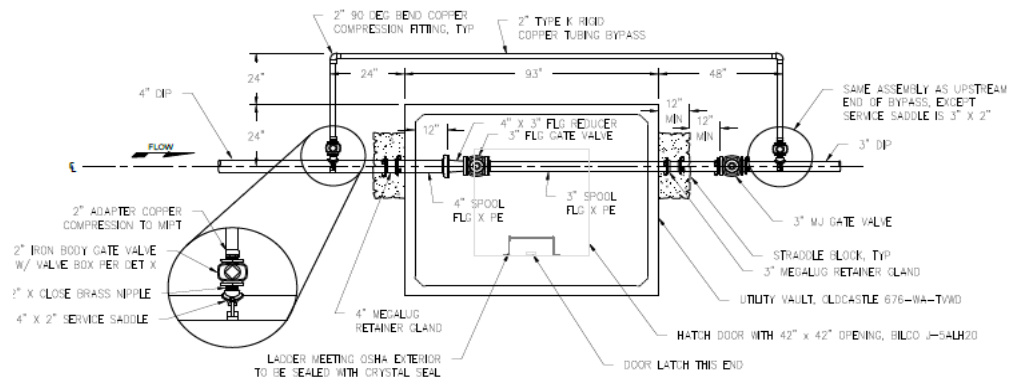

Project Description

This project aims to begin adding bypasses on some of the District's larger meters.

Project Justification

During the creation of the District's Water System Master Plan, Staff raised awareness to the fact that some of the District's (older) larger meters do not have a bypass. Not having a bypass makes it difficult for staff to test and/or replace a customer's meter without putting them out of service.

Future Operating Cost Impact

This project would speed up the process of testing and/or larger meters throughout the District. Accurate measurement of water consumed by each customer is vital to the District's ability to properly bill.

Budget Information and Projected Costs

Pre-CIP (<FY22)	FY23	FY24	FY25	FY26	FY27	FY28	Total (in CIP)	Post-CIP (>FY28)
\$ -	\$ -	\$ -	\$ -	\$ -	\$ 110,000	\$ -	\$ 110,000	\$ -

SDC Improvement Fee Eligibility: 0%

River Road



Project Description

This project designs the replacement of 6,805 feet of 4, 6, and 8-inch ductile iron pipe with 8 and 12-inch ductile iron pipe.

Project Justification

Identified by the Master Plan as a high priority backbone project that would help fire flows and meet future demand near River Road.

Future Operating Cost Impact

Completion of this project would lessen the chance of main breaks which in turn would lower operating costs.

Budget Information and Projected Costs

Pre-CIP (<FY22)	FY23	FY24	FY25	FY26	FY27	FY28	Total (in CIP)	Post-CIP (>FY28)
\$ -	\$ -	\$ -	\$ -	\$ -	\$ 329,000	\$ 1,500,000	\$ 1,829,000	\$ 1,500,000

SDC Improvement Fee Eligibility: 9.5%

Seal Coat on Valley View Reservoir Domes



Project Description

The Valley View tanks are prestressed concrete tanks and require a seal coat on the domed roofs of the two tanks to protect small surface cracks in the concrete from further deterioration. Timing of a seal coat will depend on continued monitoring of the tank roof condition through periodic inspections. Application of a seal coat is anticipated to be necessary within the next 5 to 10 years unless observed crack propagation indicates a more immediate need.

Project Justification

Preservation of the District's water storage tanks is vital to providing safe drinking water to our customers. These tanks also provide water to Clackamas River Water, Gladstone and Sunrise Water Authority customers.

Future Operating Cost Impact

This project will not change current operating costs.

Budget Information and Projected Costs

<i>Pre-CIP (<FY22)</i>	<i>FY23</i>	<i>FY24</i>	<i>FY25</i>	<i>FY26</i>	<i>FY27</i>	<i>FY28</i>	<i>Total (in CIP)</i>	<i>Post-CIP (>FY28)</i>
\$ -	\$ -	\$ -	\$ -	\$ -	\$ -	\$ 200,000	\$ 200,000	\$ -

SDC Improvement Fee Eligibility: 0%



Contact Us

Technical Services

Interim District Engineer — Jason Rice PE, jason@olwsd.org

Project Manager — Haakon Ogbeide PE, haakon@olwsd.org

Operations

Interim WRF Superintendent — David Hawkins, david@olwsd.org

Field Superintendent — Jeff Page, jeffp@olwsd.org

Water Field Supervisor — Brad Lyon, brad@olwsd.org

14496 SE River Road

Oak Grove, Oregon 97267

(503) 654-7765

oaklodgewaterservices.org